

D64RP18 SERIES B1 DIGITAL GROUND FAULT RELAY

D64RP18 INSTRUCTION MANUAL

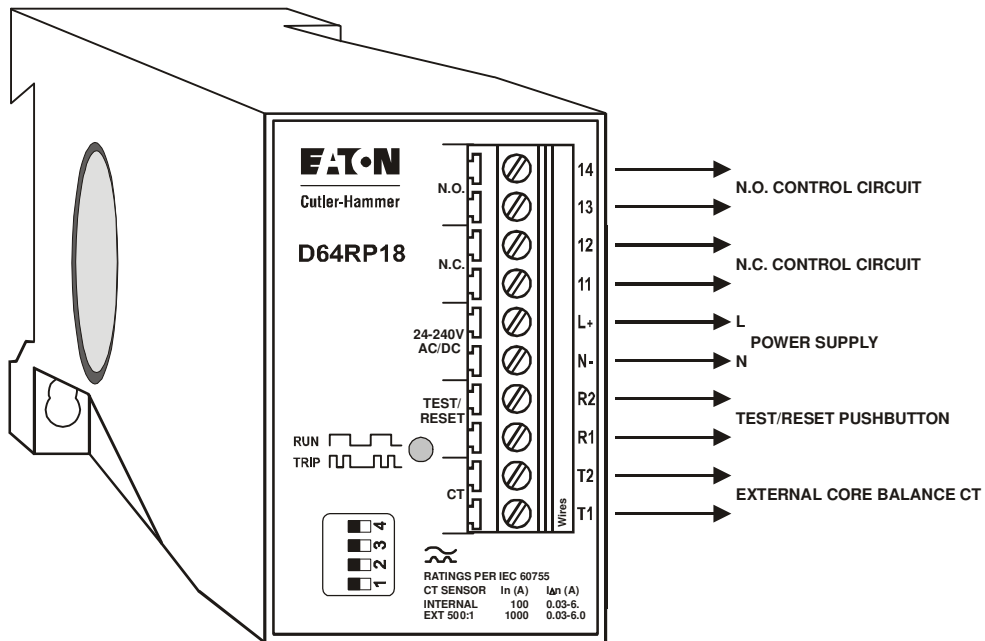

D64RP18 SERIES B1 DIGITAL GROUND FAULT RELAY

TABLE OF CONTENTS

	<u>PAGE</u>
TABLE OF CONTENTS	2
LIST OF TABLES, FIGURES & FORMS	2
1. GENERAL DESCRIPTION	3
2. OPERATION	3
2.1 GLOSSARY OF TERMS.....	3
2.2 DIPSWITCH SETTINGS	5
2.2.1 GROUND FAULT TRIP CURRENT LEVEL	6
2.2.2 GROUND FAULT TRIP DELAY TIME	6
2.3 OUTPUT RELAY OPERATING MODE.....	6
2.4 OUTPUT RELAY CONTACT STATE.....	7
2.5 INDICATION	7
2.6 RESET	7
2.7 GROUND FAULT TEST.....	7
3. INSTALLATION INSTRUCTIONS	7
3.1 MOUNTING.....	8
3.2 BUILT-IN CURRENT TRANSFORMER.....	8
3.3 EXTERNAL CURRENT TRANSFORMER.....	8
3.4 CONNECTIONS	8
3.4.1 CONNECTING MORE THAN ONE D64RP18 TO REMOTE TEST/RESET	9
4. CATALOG NUMBERS	9
5. TECHNICAL SPECIFICATIONS	10

LIST OF TABLES, FIGURES & FORMS

TABLE NO.	<u>PAGE</u>
1. DIPSWITCH SETTINGS	6
2. OUTPUT RELAY CONTACT STATES.....	13

FIGURE NO.

1. TYPICAL FIELD CONNECTION WITH BUILT-IN CT	14
2. TYPICAL FIELD CONNECTION WITH 500:1 INTERPOSING CT.....	15
3. DIMENSIONS AND WEIGHTS D64RP18 RELAY.....	16

FORM NO.

1. TEST RECORD	17
----------------------	----

D64RP18 SERIES B1 DIGITAL GROUND FAULT RELAY

1. GENERAL DESCRIPTION

The D64RP18 is a microprocessor based ground fault relay for use on solidly grounded or resistance grounded systems. This innovative digital electronic relay measures ground fault current using a built-in 1.1" zero sequence current transformer (CT).

The D64RP18 reacts to alternating current only and will reject direct current signals. It will maintain accuracy over a frequency range of 45 to 450Hz, making it suitable for variable frequency drive applications.

660 Volts is the maximum system operating voltage for the D64RP18 when passing the system power conductors through the built-in CT. However, by using any Eaton's Cutler-Hammer C311CT zero sequence current transformers with 500:1 ratio, connecting the secondary to terminals T1 and T2 of the relay, and passing the system insulated power conductors through the window of this CT, the D64RP18 can be applied on any system voltage.

The ground fault current trip level is set on a front accessible binary DIPswitch array. Trip currents from 30 milliamps - 6 Amps can be selected in 8 discrete steps. These same trip settings are available when using any C311CT 500:1 ratio external CT. The trip level can be set just above the charging current¹. Any deterioration in the circuit will trip the relay. This also permits scheduled field testing of the relay (by lowering the trip level).

¹ The capacitance-to-ground charging current on a system will vary depending on: the overall length of the cables; the types of loads; the quality of insulation on the phase conductors; the surrounding equipment grounding, cable trays, junction boxes, etc.; and, the type of transformer.
A "Rule-of-Thumb" for systems 600 Volts and lower: The charging current is 0.5 Amps per 1000 kVA of transformer capacity.

The response time on ground fault trip is set on a single front accessible DIPswitch. The two settings are instantaneous (20 ms) or 500 ms.

The output relay has Form "Z" (4 terminal) N.O. and N.C. contacts which may be used to operate the upstream protective device and to indicate a failure of the system. The relay will operate in one of two modes: Non-failsafe; or Pulsed Output Auto Reset. The mode is established by the type of pushbutton (or jumper) connected to terminals R1 and R2: N.O. = Non-failsafe; N.C. (or jumper) = Pulsed Output Auto Reset.

By double clicking the remote RESET button connected to terminals R1 and R2, a functional test of the D64RP18 is invoked. A single press of a N.O. contact remote RESET button resets the relay after a trip. (It is not necessary to press a N.C. contact remote RESET to invoke Auto Reset). The green LED indicates two functions: When slow flashing it denotes control power is applied to terminals N- and L+; when fast blinking it denotes the relay has sensed a ground fault current higher than the trip level for a period longer than the trip time and that the output contacts have operated.

A 10 point Pull-apart terminal block simplifies connection of field wiring.

The D64RP18 operates on any control voltage from 24 to 240 Volts ac or dc.

2. OPERATION**2.1 GLOSSARY OF TERMS****Manual Reset:**

A N.O. contact remote RESET pushbutton connected to terminals R1 and R2 of the D64RP18 must be pressed once to reset the output relay after a trip, providing the ground fault has been cleared or the measured values are within the preset limits.

D64RP18 SERIES B1 DIGITAL GROUND FAULT RELAY

Pulsed (Trip) Auto Reset:

Each time control power is applied, the internal processor of the D64RP18 selects this mode when it sees a closed circuit on terminals R1 & R2 (there is a jumper or a N.C. pushbutton connected to R1 and R2). In this mode the N.C. button does not perform a reset function.

The output relay N.O. contact is closed when tripped and the N.C. contact is open when tripped.

The output relay does not change state when control power is applied to terminals N- & L+.

With control voltage on terminals N- & L+ (Green LED slow flashing), when the measured values reach or exceed the DIPswitch settings for current and time, the output relay changes state (trips) and the green LED changes to fast blinking. The output relay will remain tripped until one of the following conditions is met:

- Three seconds after the ground fault current drops below the trip current set point the relay will reset and the green LED resumes slow flashing. This is, in effect, Pulsed Auto Reset.
- If the control voltage is removed by the trip action of the output relay (i.e. it operates the shunt trip of the breaker that is providing the control voltage), the relay will reset with a short delay and the green LED is turned off. This is, in effect, Auto Reset.

If the ground fault has not been cleared when control voltage is restored, the relay will trip and the green LED will resume fast blink after 500 milliseconds, regardless of the time delay set on the Trip Delay DIPswitch, and the above cycle will be repeated.

If the ground fault has been cleared when control voltage is restored, the relay will remain reset.

The Pulsed Trip Auto Reset mode can be used when the application calls for Auto Reset.

The Pulsed Trip Auto Reset mode is designed for applications where the output relay is operating a shunt trip device. The D64RP18 resets automatically 3 seconds after the ground fault current is interrupted by the tripping action of the circuit breaker. The output contact to the shunt trip coil opens. This prevents damage to the internal mechanism of the circuit breaker in the event that the operator tries to reset the circuit breaker. When the control voltage to the D64RP18 is interrupted by action of the shunt trip, the D64RP18 resets with a short delay.

Non-Failsafe:

Each time control power is applied, the internal processor of the D64RP18 selects this mode when it sees an open circuit on terminals R1 & R2 (there is no contact or a N.O. pushbutton is connected to R1 and R2).

The output relay N.O. contact is closed when tripped and the N.C. contact is open when tripped.

The output relay does not change state when control power is applied to terminals N- & L+.

With control voltage on terminals N- & L+ (Green LED slow flashing), when the measured values reach or exceed the DIPswitch settings for current and time, the output relay changes state (trips) and the green LED changes to fast blinking.

D64RP18 SERIES B1 DIGITAL GROUND FAULT RELAY

If control voltage is maintained on terminals N- & L+ after a ground fault trip, the RESET button must be pressed to reset the relay after clearing the ground fault.

If control voltage is removed from terminals N- & L+ while a ground fault is detected, the output relay resets and the green LED is turned off.

If the ground fault has not been cleared when control voltage is restored, the relay will trip and the green LED will resume fast blinking after 500 milliseconds, regardless of the time delay set on the Trip Delay DIPswitch.

If the ground fault has been cleared when control voltage is restored, the relay will remain reset.

The Non-Failsafe mode can be used when the output relay is operating undervoltage devices. This includes: contactor coils; starter coils; and circuit breakers equipped with UV trip coils.

External Current Transformer:

External current transformers (CTs) are required for any of the following applications:

- The size of the power conductors on which the D64RP18 is being applied is too large for the 1.1" built-in CT.
- The system voltage on which the D64RP18 is being applied is higher than 660 Volts.
- The system primary phase current on which the D64RP18 is being applied exceeds 100 Amps continuous.

Any Eaton's Cutler-Hammer C311CT with 500:1 ratio may be used when the above requirements dictate the use of an external CT. The ground fault trip current setting range of 30 mA – 6 Amps in 8 steps is the same. The maximum continuous primary phase current is to be 1000 Amps.

The two secondary terminals of the external CT are to be connected to terminals T1 and T2 of the D64RP18.

Chassis Ground

Chassis ground is the ground to which all of the non-current carrying metal equipment is connected/bonded. Typically, equipment grounding is provided by means of a ground bus. A solid connection is to be made from terminal N- of the D64RP18 to the nearest chassis ground to ensure the relay complies with the specified Electromagnetic compatibility (EMC) standards.

2.2 DIPSWITCH SETTINGS

FOR MAXIMUM SAFETY THE SETTINGS DESCRIBED IN THIS SECTION SHOULD BE MADE WITH CONTROL VOLTAGE REMOVED FROM THE D64RP18 RELAY.

The DIPswitches are mounted inside of the relay and are accessible through the front cover. It is recommended that all of the DIPswitches be set at one time.

Should it be necessary to make changes to the DIPswitch settings when the D64RP18 relay is energized, this can be done without having any adverse effect on the performance of the relay.

Please Refer to Table 1 on the next page. This provides a list of the 4 DIPswitches, the function of each group, and the values related to each setting. The DIPswitches are numbered from 1 to 4 bottom to top.

D64RP18 SERIES B1 DIGITAL GROUND FAULT RELAY

TABLE 1 – DIPSWITCH SETTINGS

In the table below 'R' denotes right and 'L' denotes left.

Switch	Function	Set to	Meaning
1 2 3	Ground fault trip current limit	R L L	30 mA
		R L R	120 mA
		R R L	210 mA
		R R R ♦	300 mA
		L L L	600 mA
		L L R	2.4 Amps
		L R L	4.2 Amps
		L R R	6.0 Amps
4	Trip time delay	R ♦	Instantaneous (20 ms)
		L	500 ms
♦ FACTORY SETTING			

2.2.1 GROUND FAULT TRIP CURRENT LEVEL - DIPSWITCHES 1, 2, & 3

The ground fault TRIP LEVEL range is 30 mA - 6 Amps. Table 1 provides a listing of the eight TRIP LEVEL settings, which can be made on DIPswitches 1, 2, & 3.

As indicated in the General Description, it is recommended that the ground fault TRIP LEVEL setting be kept as close to the charging current as possible. This will provide maximum safety for operating personnel and equipment protection. On resistance grounded systems, the TRIP LEVEL setting should be set lower than 20% of the Neutral Grounding Resistor let-through current.

If the measured ground fault current exceeds the TRIP LEVEL setting, the output relay changes state after the pre-selected TRIP DELAY time.

2.2.2 GROUND FAULT TRIP DELAY TIME – DIPSWITCH 4

The ground fault TRIP DELAY time can be set at Instantaneous (20 ms) or 500 ms with DIPswitch 4.

The TRIP DELAY time begins when the ground fault trip level setting is reached or is exceeded. Set the ground fault TRIP DELAY time to provide the desired delay before the output relay changes state when the ground fault TRIP LEVEL setting is reached or exceeded.

The setting should be selected to co-ordinate with other ground-fault devices connected on the same transformer secondary: set shorter than upstream devices; set longer than downstream devices. If no other ground-fault devices are connected, set for the shortest time.

2.3 OUTPUT RELAY OPERATING MODE

Referring to the Glossary of Terms, determine if NON-FAILSAFE or PULSED TRIP AUTO RESET operation of the output relay is required.

For Non-Failsafe operation leave terminals R1 and R2 open or connect a N.O. momentary contact TEST/RESET button to these terminals.

For Pulsed Trip Auto Reset operation install a jumper between terminals R1 and R2 or connect a N.C. momentary contact TEST button to these terminals.

D64RP18 SERIES B1 DIGITAL GROUND FAULT RELAY

2.4 OUTPUT RELAY CONTACT STATE

The output relay contact state is determined by the operating mode selected and the sensing condition of the D64RP18 relay. This is shown in Table 2. Use this table when deciding on field connections. Refer to the CONNECTIONS section.

2.5 INDICATION

There is one green LED on the front of the D64RP18:

Off:	No control voltage or D64RP18 defective
Slow Flashing:	Okay, control voltage on
Fast Blinking:	Ground Fault Trip
Steady On:	Control voltage too low or D64RP18 defective

2.6 RESET

The D64RP18 has two terminals R1 and R2 for a remote N.O. Reset button. After a trip, the electronics remain in the tripped state until the ground fault has been cleared and the Reset button has been pressed, or the control voltage is removed from terminals L- & N+.

It is **NOT** necessary to press the N.C. remote button after the ground fault has been cleared when the D64RP18 is set in the Pulsed Trip Auto Reset mode. In this mode the relay will reset automatically in 3 seconds.

2.7 GROUND FAULT TEST

Double clicking the external button connected to terminals R1 and R2 invokes a relay test. A simulated current equal to 1.2 times the trip current set on the Trip Level DIPswitches replaces the measured current. After the trip delay time set on the Trip Delay DIPswitch has elapsed, the unit should trip and the green LED will fast blink. This procedure tests the functionality of the unit.

After the trip, if the external button is N.O. (the trip mode is Non-Failsafe), the output relay will remain tripped and the green LED will fast blink until the button is pressed (Manual Reset)

After the trip, if the external button is N.C. or there is a jumper on terminals R1 and R2 (the trip mode is Pulsed Trip Auto Reset), the output relay will reset and the green LED will revert to slow flash 3 second after the test was invoked (Auto Reset)

A "Test Record Form" is included in this instruction manual. This form provides spaces to record the date the test was performed and the results. Those in charge of the building's electrical installation should retain the form in order to be available to the authority having jurisdiction.

3. INSTALLATION INSTRUCTIONS

Place the D64RP18 in a clean dry enclosure. Try to keep the exposure to mechanical shock and vibration to a minimum, even though the internal electronics have been encapsulated in epoxy to improve the performance in high vibration environments.

Locate the relay close to the isolating device (circuit breaker or contactor) that is protecting the circuit being monitored. If using an external CT keep the distance between the relay & CT as short as possible.

Provide maximum clearance between the D64RP18 (and the external CT if being used) and any strong magnetic flux producing devices such as power transformers, autotransformers, control transformers, reactors, and high power conductors and buswork.

CAUTION: For reliable ground fault detection by the D64RP18 use one CT configuration only: Built-in CT; or, External CT (i.e. do not pass power conductors through the built-in CT when using an external CT.)

3.1 MOUNTING

D64RP18 SERIES B1 DIGITAL GROUND FAULT RELAY

Refer to Figure 3 for mounting dimensions of the D64RP18 relay. It is designed to be mounted with either mounting screws or 35 mm DIN rail.

Two #8-32 x 3/4" (M4 x 20) mounting screws are required for screw mounting.

For DIN rail mounting the rail should be bolted to a flat surface. Install the DIN rail horizontally. Allow at least 3/4" (20 mm) of rail to extend beyond each end of the relay. Secure the relay to the DIN rail ensuring the white release latch at the bottom of the relay engages the rail. If the relay is to be mounted in any other position take appropriate steps to prevent the relay from becoming disengaged from the DIN rail.

3.2 BUILT-IN CURRENT TRANSFORMER

The D64RP18 has a built-in current transformer (CT) with 1.1" (28 mm) opening.

Refer to Figure 1. Pass the phase conductors through the CT window. If the neutral conductor is carrying single phase current, it is to be passed through the window. Do not pass ground conductors through the CT window. In applications that require shielded wires to pass through the CT window, return the shields through the CT window before connecting them to ground.

Verify that the polarity of the conductors is correct when they pass through the CT. Verify that ground paths do not exist that would bypass the CT.

The D64RP18 Trip Level range is 30 mA to 6.0 Amps when using the built-in CT. The maximum continuous primary phase current is to be 100 Amps.

3.3 EXTERNAL CURRENT TRANSFORMER

Refer to the Glossary of Terms to determine if an external Current Transformer is required for the application.

The D64RP18 will work with Eaton's Cutler-Hammer C311CT current transformers having a turns ratio of 500:1. These are epoxy molded to give exceptional mechanical properties and have high-grade silicon iron cores for excellent coupling characteristics.

Refer to section 4 to select the catalog number of the C311CT current transformer with the opening required for the application.

Phase conductors must be insulated for the system voltage when it is higher than 660 Volts.

Refer to Figure 2. Pass the phase conductors through the CT window. If the neutral conductor is being connected downstream, it is to be passed through the window. Do not pass ground conductors through the CT window. In applications that require shielded wires to pass through the CT window, return the shields through the CT window before connecting them to ground.

Verify that the polarity of the conductors is correct when they pass through the CT. Verify that ground paths do not exist that would bypass the CT.

Position power cables in the center of the current transformer opening. Keep cables and buswork clear of the split on split core current transformers.

The two secondary terminals of the external CT are to be connected to terminals T1 and T2 of the D64RP18.

3.4 CONNECTIONS

All connections to the D64RP18 are by means of screw clamp terminals rated 10 Amps, 300 Volts. Terminals will accept #26-12 AWG solid or stranded conductors.

D64RP18 SERIES B1 DIGITAL GROUND FAULT RELAY

The terminals are pull apart.

If an external CT is being used, connect the two secondary terminals of the CT to terminals T1 and T2 of the relay using 14 AWG (minimum). Twist the leads to optimise electromagnetic immunity.

Note: The CT's input terminals T1 and T2 are NOT isolated from the control voltage. If an external CT is used it is grounded internally via the power supply input and **must not** be grounded again externally (ground loops).

For Non-Failsafe operation leave terminals R1 and R2 open or connect a N.O. momentary contact TEST/RESET button to these terminals.

For Pulsed Trip Auto Reset operation install a jumper between terminals R1 and R2 or connect a N.C. momentary contact TEST button to these terminals.

Note: Terminals R1 and R2 are NOT isolated from the control voltage; terminal R2 is internally connected to terminal N-.

Connect ac or dc control power to terminals N- and L+. Observe polarity.

In order to meet the Electromagnetic Compatibility (EMC) requirements a chassis bond is required between terminal N- and the nearest ground point. This distance should be kept to an absolute minimum. If the D64RP18 is mounted on 35 mm DIN rail a DIN rail mounted ground terminal block can be installed beside the relay to act as the chassis ground point.

Refer to Figure 1, Figure 2, and Table 2. Decide on the connection of field devices to control voltage and output relay contact terminals by comparing the desired control of the field devices under various operating conditions.

Figure 1 shows the D64RP18 using its built-in current transformer and a typical connection of an ac motor starter coil (1M). A remote Reset button with N.O. contacts is connected to terminals R1 and R2 providing Non-Failsafe operating mode. Comparing the operating mode and the output relay contact states in Table 2, it can be seen that the N.C. contact, terminals 11 & 12, would be used for the starter coil circuit and the N.O. contact, terminals 13 and 14, would control the external red TRIP light. A manual reset is required after a ground fault trip

Figure 2 shows the D64RP18 using an external current transformer (C311CT 500:1 ratio) and a typical connection of a circuit breaker with a shunt trip coil (ST). A remote pushbutton with N.C. contacts is connected to terminals R1 and R2, providing Pulsed Trip Auto Reset operating mode. Comparing the operating mode and the relay contact states in Table 2, it can be seen that the N.O. contact, terminals 13 and 14, would be used for the shunt trip coil. The D64RP18 will reset automatically as soon as the ground fault current is interrupted by the tripping action of the circuit breaker.

3.4.1 CONNECTING MORE THAN ONE D64RP18 TO REMOTE TEST/RESET

Up to 5 D64RP18 relays in the same enclosure may share a common remote Test/Reset button. Connect one terminal of the button to terminal R2 of one of the units, and connect the other terminal of the button to terminals R1 of all the units in parallel.

Those relays that are to operate in the Pulsed Trip Auto Reset mode should have the R1 terminal of all units connected to a N.C. Button. Those relays that are to operate in the Non-Failsafe mode should have the R1 terminal of all units connected to a N.O. Button.

4. CATALOG NUMBERS

D64RP18 Ground Fault Relay with built-in 1.1" (28mm) CT, 24 – 240 Volts ac or dc control voltage, for use on 660 Volts maximum, 50/60 Hz power system.

D64RP18 SERIES B1 DIGITAL GROUND FAULT RELAY

C311CT8	Zero sequence current transformer, 1.1" window
C311CT1	Zero sequence current transformer, 1.8" window
C311CT9	Zero sequence current transformer, 2.56" window
C311CT2	Zero sequence current transformer, 3.5" window
C311CT5	Zero sequence current transformer, 5.7" window
C311CT6	Zero sequence current transformer, 9.45" window
C311CT3	Split core zero sequence current transformer, 5.9" x 6.7" window
C311CT4	Split core zero sequence current transformer, 4" x 13.8" window

For mounting dimensions and additional information on C311CT current transformers refer to the current Eaton's Cutler-Hammer catalog.

5. TECHNICAL SPECIFICATION

Control Voltage (non-isolated).....	24 – 240 Volts ac or dc
Power consumption	proportional to voltage: 0.15 W @ 24 V ac/dc 1.5 W @ 240 V ac/dc
Operating voltage tolerance.....	80% to 110% of rated voltage 24 -32 V ac 55% to 110% of rated voltage 32 – 240 V ac 80% to 110% of rated voltage 24 – 240 V dc
Under voltage tolerance (no impaired operation)	withstands loss of supply up to 100 ms
Power Up Time	500 milliseconds
Maximum System Voltage & Frequency.....	660 Volts ac, 45 to 450 Hz

The D64RP18 may be applied on higher voltage circuits providing an external current transformer is used and the power conductors are insulated for the system voltage.

Output Relay:

Contacts:	Maximum UL rating:	5 A @ 250 Vac, general use 5 A @ 30 Vdc, resistive 1/8 hp, 250 Vac 2 A, 250 VA, @ 125 Vac, pilot duty 1 A, 250 VA, @ 250 Vac, pilot duty 0.88 A, 26.4 VA, @ 30 Vdc, pilot duty
	EN 60947-5-1 rating:	5 A @ 250 Vac, Utilization category AC-12 4 A @ 250 Vac, Utilization category AC-13 3 A @ 250 Vac, Utilization category AC-14, AC15 5 A @ 30 Vdc, Utilization category DC-12 3 A @ 24 Vdc, Utilization category DC-13
	Maximum fusing under EN 60947-5-1:	13 A
	Isolation voltage	3 kV rms, 50-60 Hz, 1 min.
	Between open contacts	1 kV rms, 50-60 Hz, 1 min.
	Between contact sets	2 kV rms, 50-60 Hz, 1 min.
	Configuration.....	Voltage free form "Z" 1 N.O. and 1 N.C. (4 terminals)
	Operating Mode (Selected by connections on terminals R1 and R2).....	Non-Failsafe Pulsed Auto Reset

Functional Test:

D64RP18 SERIES B1 DIGITAL GROUND FAULT RELAY

A simulated current equal to 120% of the trip current set on the Trip Level DIPswitches replaces the measured current. This tests all internal electronics and secondary winding of the built-in current transformer. No external power supply or additional wiring is required.

Remote Test Double click button connected to terminals R1 and R2
 Remote Reset (Non-Failsafe mode only) N.O. Reset button connected to terminals R1 and R2
 Reset mode Manual or Pulsed Auto Reset

Ground Fault Circuit:

Ground Fault Trip Time Delay..... 20 or 500 milliseconds
 Setting DIPswitch 4 on front of relay

Accuracy:

Has a current dependent behavior:

<u>If set for</u>	<u>Delay when current exceeds trip current setting by a factor of</u>			
	<u>1.2</u>	<u>2</u>	<u>4</u>	<u>≥6</u>
20 ms	59-91 ms	36-54 ms	25-41 ms	19-35 ms
500 ms	546-579 ms	523-542 ms	512-529 ms	506-523 ms

Ground Fault Trip Current Level 30 mA – 6.0 Amps in 8 settings: 30mA, 120mA, 210mA, 300mA, 600mA, 2.4Amps, 4.2Amps, and 6.0Amps

Setting within the Range DIPswitches 1, 2, & 3, on front of relay
 Accuracy +0%, -15% of trip setting

Note: The accuracy of the trip point refers to the value of the real world current (assuming a purely sinusoidal wave shape) that just causes a trip, with respect to the specified value in the table.

Frequency Response Range 45 - 450 Hz

Thermal Characteristics:

Short Time Withstand:
 1000A..... 1 second
 2000A..... 0.1 second

Environment:

Operating Temperature..... -35°C to +60°C
 Storage -40°C to +80°C
 Humidity 85% (No Condensation)

Shock resistance 10G (no malfunction)

Vibration resistance 10G, 10-55 Hz at 1.5 mm double amplitude (no malfunction)

Ingress protection IP20

Dimensions (refer to Figure 3):

Height..... 2.76" (70 mm)
 Width..... 1.77" (45 mm)
 Depth (not including terminal blocks)..... 3.58" (91 mm)
 Depth (including terminal blocks)..... 4.43" (112.5 mm)

Mounting (refer to Figure 3):

DIN rail 35 mm

D64RP18 SERIES B1 DIGITAL GROUND FAULT RELAY

Weight:	Two Screw	#8 x 3/4" (M4 x 20 mm)
	Open	0.88 lbs. (0.40 kg)
	Packaged	1.08 lbs. (0.49 kg)

Applicable Standards:

EN 61000-6-3	Electromagnetic compatibility (EMC) - Part 6-3 Generic standards– Emission standard for residential, commercial and light-industrial environments (note: = lowest levels): 30-230 MHz 30 dB μ V at 10m distance 230-1000 MHz 37 dB μ V at 10m distance
EN 61000-6-2	Electromagnetic compatibility (EMC) - Part 6-2 Generic standards– Immunity standard for industrial environments (note: = highest levels): 80-1000 MHz with 80% AM modulation up to 10 V/m at 3m distance from source
EN 61000-4-2	Electromagnetic compatibility (EMC) for industrial-process measurement and control equipment – Part 4-2: Electrostatic discharge (ESD) immunity
EN 61000-4-3	Electromagnetic compatibility (EMC) for industrial-process measurement and control equipment – Part 4-3: Radiated electromagnetic field immunity
EN 61000-4-4	Electromagnetic compatibility (EMC) for industrial-process measurement and control equipment – Part 4-4: Electrical fast transient/burst immunity
EN 61000-4-5	Electromagnetic compatibility (EMC) for industrial-process measurement and control equipment – Part 4-5: Surge immunity
EN 61000-4-6	Electromagnetic compatibility (EMC) for industrial-process measurement and control equipment – Part 4-6: Conducted radio frequency field immunity
EN 61000-4-11	Electromagnetic compatibility (EMC) for industrial-process measurement and control equipment – Part 4-11: Voltage dips/drops/variations immunity
EN 60947-5-1	Low-voltage switchgear and controlgear – Part 5-1: Control circuit devices and switching elements – Electromechanical control circuit devices
IEC 60755	General requirements for residual current operated protective devices
UL	UL 1053 Ground-Fault Sensing and Relaying Equipment, Class 1 UL File E195341
CSA	C22.2 No. 144-M91 Ground Fault Circuit Interrupters CSA File 700103
CE	CE mark – Declaration of Conformity

External Current Transformer (when required)

Use Eaton's Cutler-Hammer C311CT series with 500:1 ratio, listed in section 4 – Catalog Numbers.

D64RP18 SERIES B1 DIGITAL GROUND FAULT RELAY

TABLE 2 – OUTPUT CONTACT STATES

STATE OF OUTPUT RELAY CONTACTS UNDER VARIOUS OPERATING CONDITIONS WITH OPEN OR CLOSED CONTACTS CONNECTED TO TERMINALS R1 AND R2

OPERATING CONDITIONS		NON-FAILSAFE Open Contacts on Terminals R1 & R2				PULSED AUTO RESET Closed Contacts on Terminals R1 & R2			
		13	14	11	12	13	14	11	12
1. CONTROL POWER OFF		+	+	—	—	+	+	—	—
2. CONTROL POWER ON		+	+	—	—	+	+	—	—
3. CONTROL POWER ON, FAULT CURRENT ABOVE TRIP SETTING & TRIP TIME		—	—	+	+	—	—	+	+
4. CONTROL POWER ON, FAULT CLEARED	NO RESET REQUEST	—	—	+	+	—	—	+	+
	RESET REQUEST	+	+	—	—	Not Required	Not Required	+	+
5. CONTROL POWER OFF, FAULT STILL ON SYSTEM		+	+	—	—	+	+	—	—
6. CONTROL POWER RESTORED, FAULT STILL ON SYSTEM		+	+	—	—	+	+	—	—
		+ 500 ms	+ 500 ms	+ 500 ms	+ 500 ms	=	=	=	=
7. CONTROL POWER RESTORED, FAULT CLEARED WHILE CONTROL POWER OFF, WITH OR WITHOUT RESET		+	+	—	—	+	+	—	—

D64RP18 SERIES B1 DIGITAL GROUND FAULT RELAY

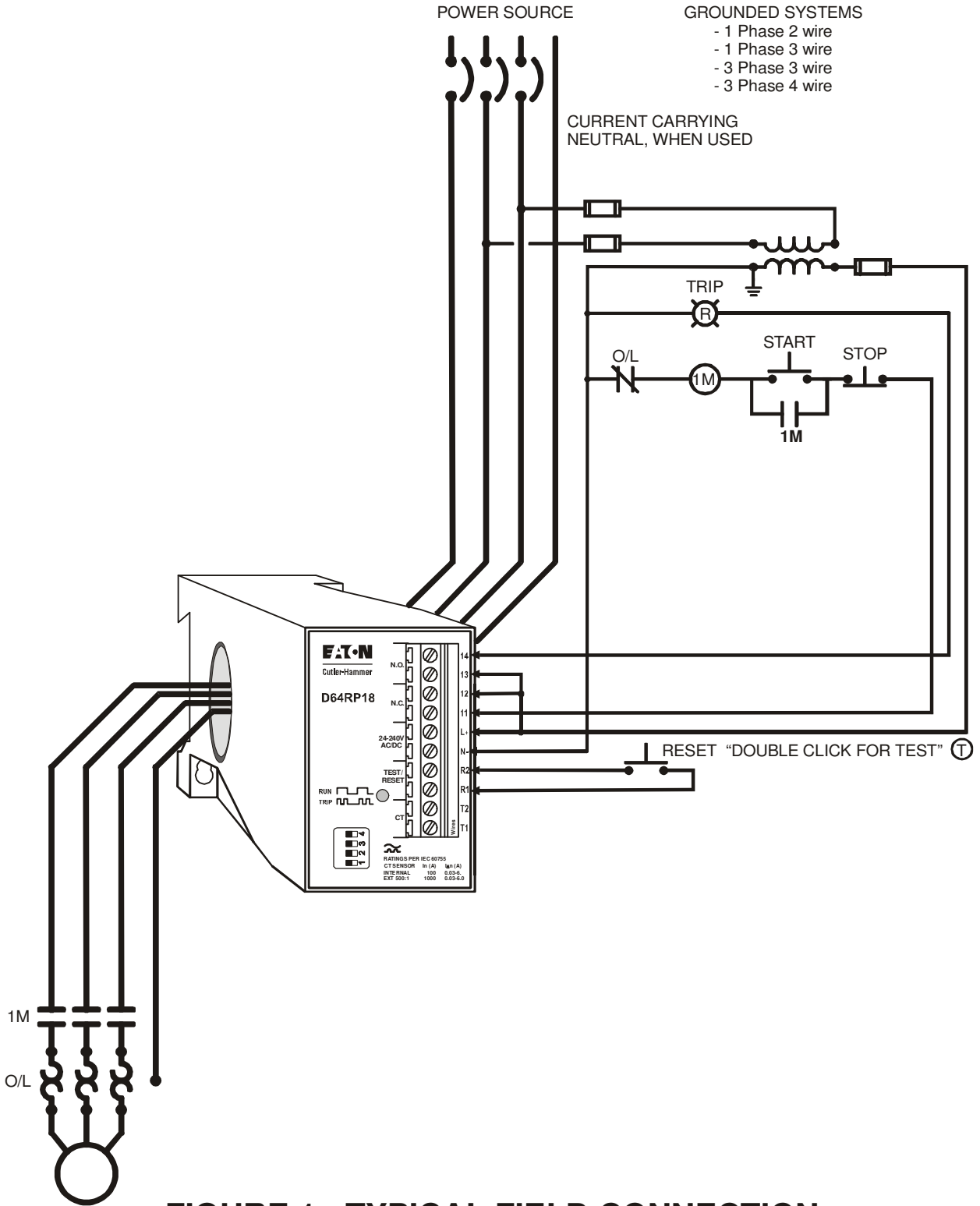

FIGURE 1 - TYPICAL FIELD CONNECTION USING BUILT IN CORE BALANCE

D64RP18 SERIES B1 DIGITAL GROUND FAULT RELAY

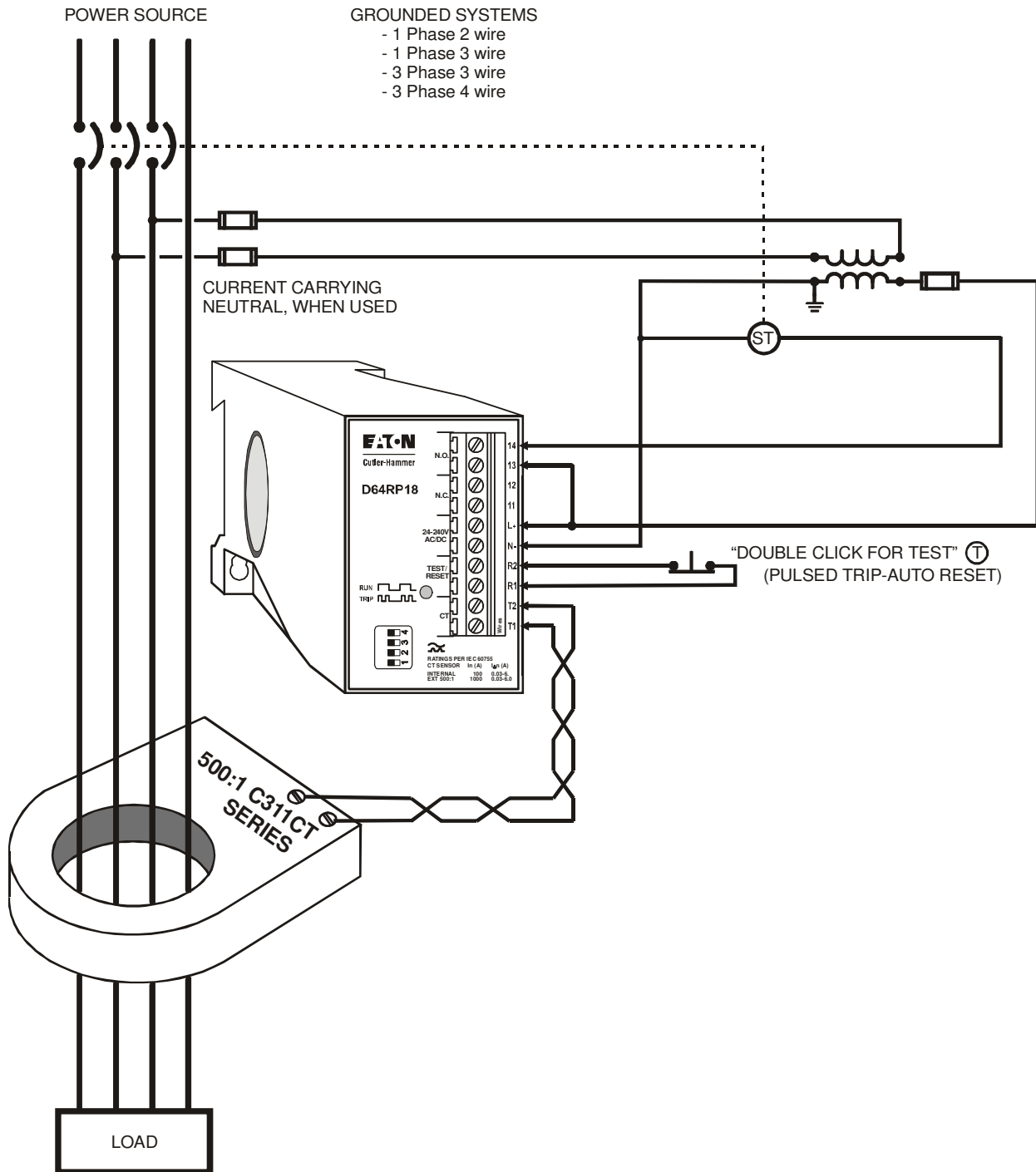
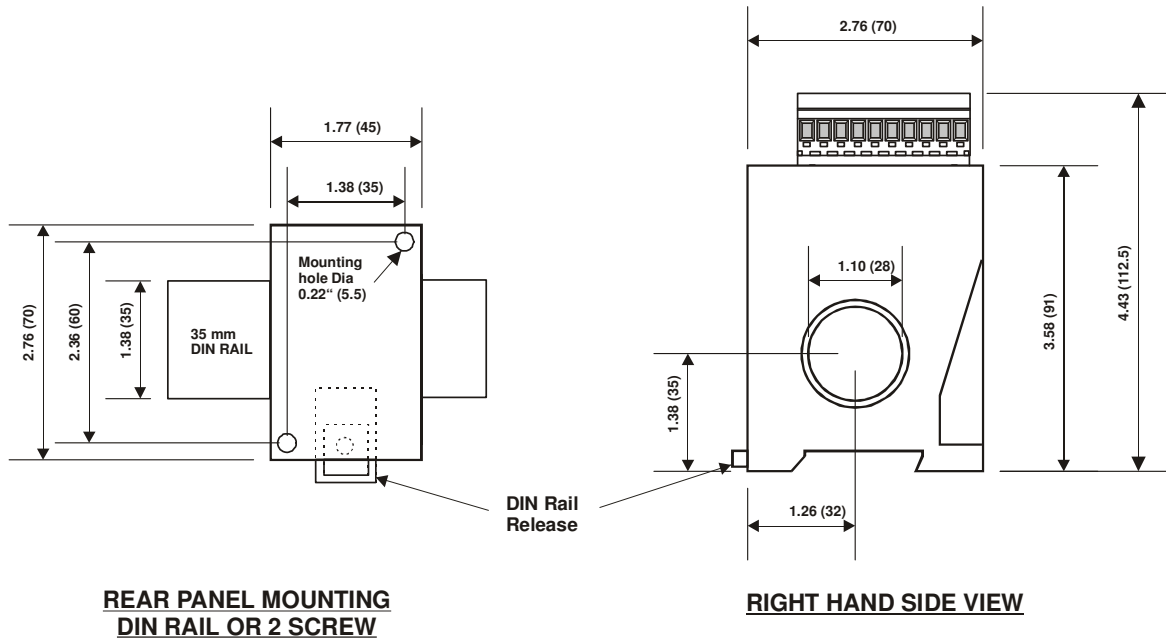

FIGURE 2 - TYPICAL FIELD CONNECTION WITH EXTERNAL 500:1 CURRENT TRANSFORMER AND PULSED TRIP-AUTO RESET

D64RP18 SERIES B1 DIGITAL GROUND FAULT RELAY

FIGURE 3 - DIMENSIONS AND WEIGHTS D64RP18



OPEN WEIGHT: 0.88 LBS. (.40KG)
PACKAGED WEIGHT: 1.08 LBS. (.49 KG)

DIMENSIONS ARE IN INCHES (MM IN BRACKETS)

